

Mechanical Dimensions: Inches [mm]

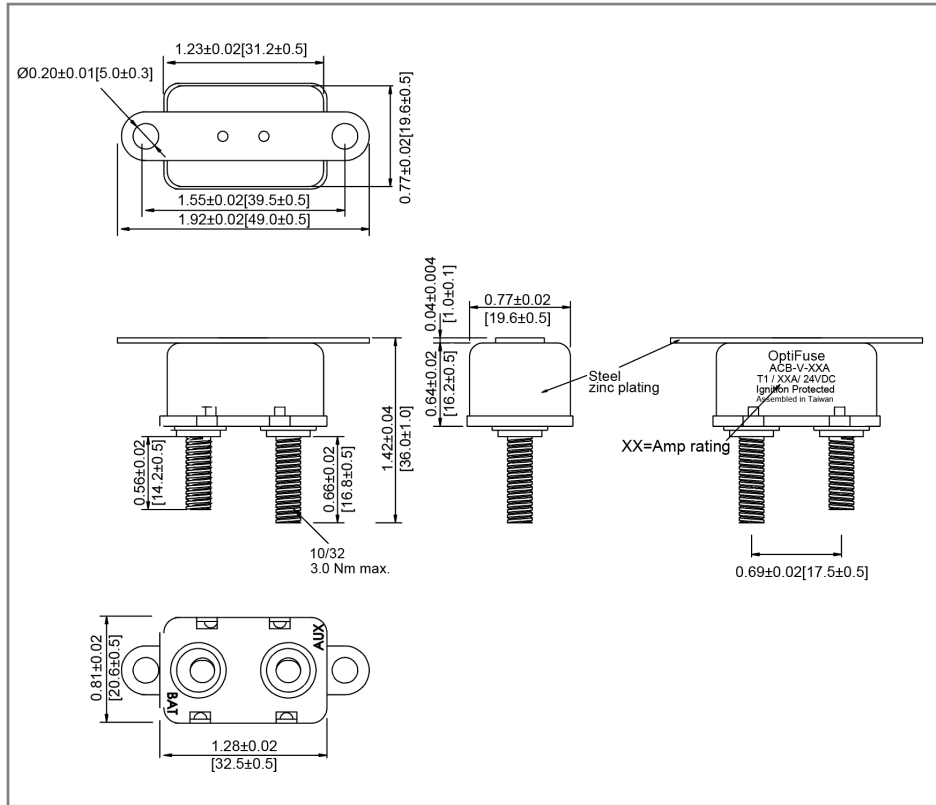

Part Numbers Information

Amperage	Optifuse P/N
5A	ACB-V-5A
6A	ACB-V-6A
8A	ACB-V-8A
10A	ACB-V-10A
12A	ACB-V-12A
15A	ACB-V-15A
20A	ACB-V-20A
25A	ACB-V-25A
30A	ACB-V-30A
35A	ACB-V-35A
40A	ACB-V-40A
45A	ACB-V-45A
50A	ACB-V-50A

Time vs. Percent of Rated Current

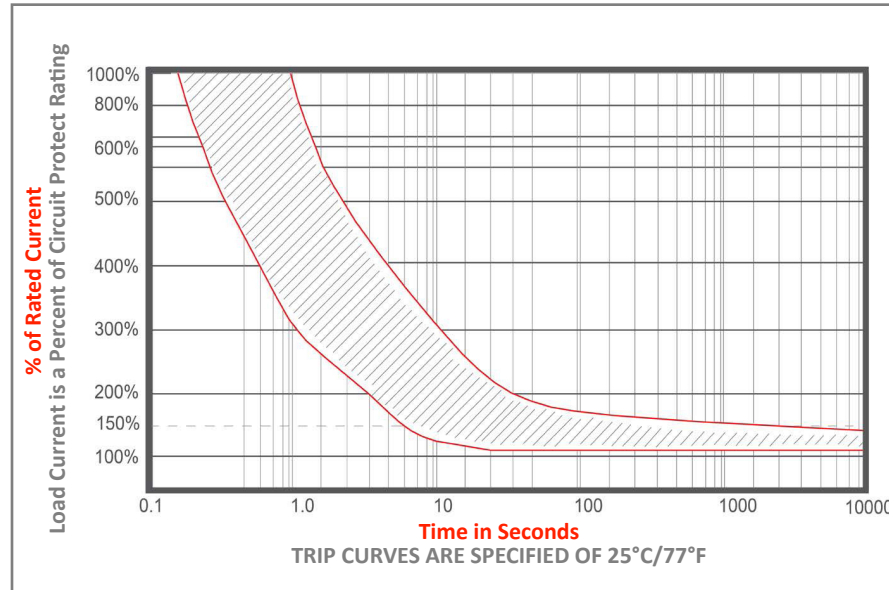

% of Rated Current	Min Trip Time	Max Trip Time
100%	Hold	No Trip
150%		Trip in 1 hr
200%	4.0s	40.0s
300%	1.2s	12.0s
400%	0.6s	5.0s
500%	0.4s	2.8s
600%	0.3s	1.8s

Electrical Specifications

Voltage Rating	12/24/32VDC
Reset Type	Type I - Auto Reset
Interrupting Rating	4 Times Rated Current
Operation Temperature	-10°C ~ 60°C
Testing	SAE J553

Material Specifications

Body Material	Steel, Zinc plating
Terminals Material	Battery – Copper Plated, Auxiliary – Zinc Plated
Terminals Configuration	#10-32 stud
Studs Torque	3.0 ± 0.3 N.m
Mounting Torque	1.0 ± 0.1 N.m
Ignition Protection	SAE J1171

Temperature Derating Curve

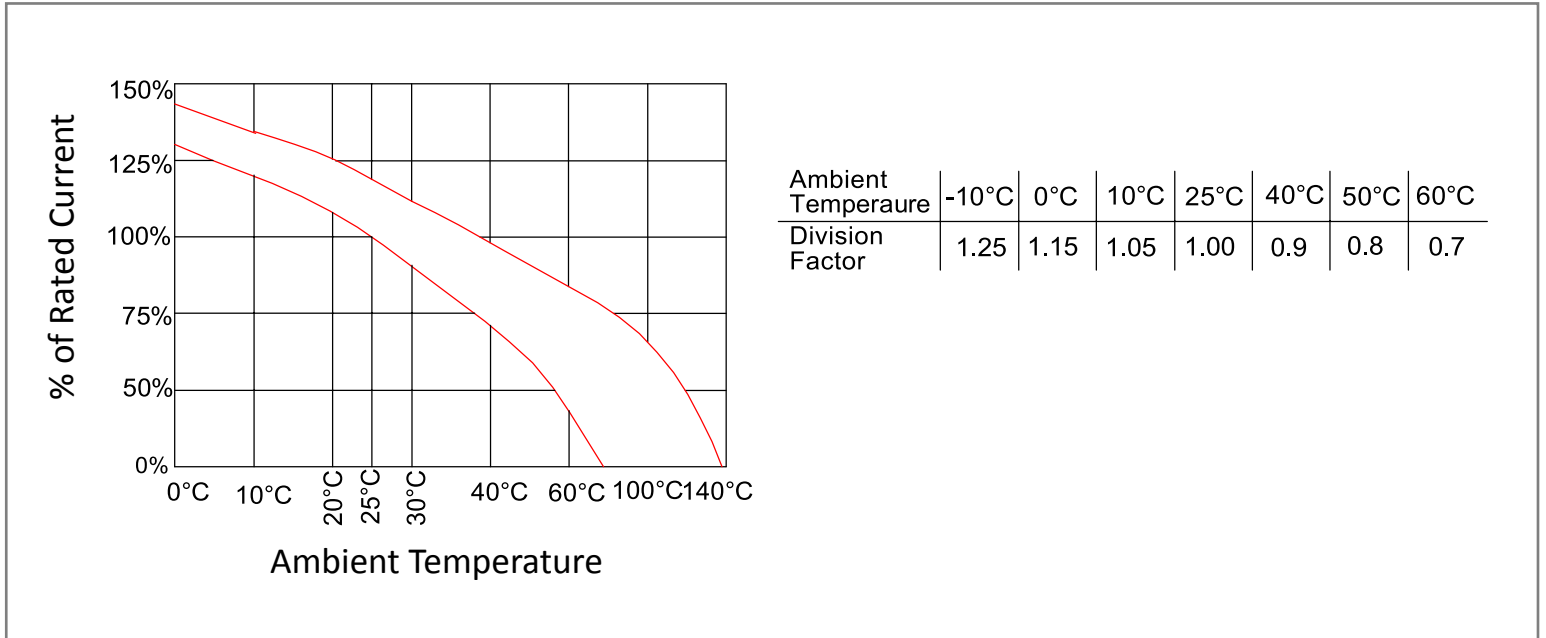

Retail Pack: Inches [mm]

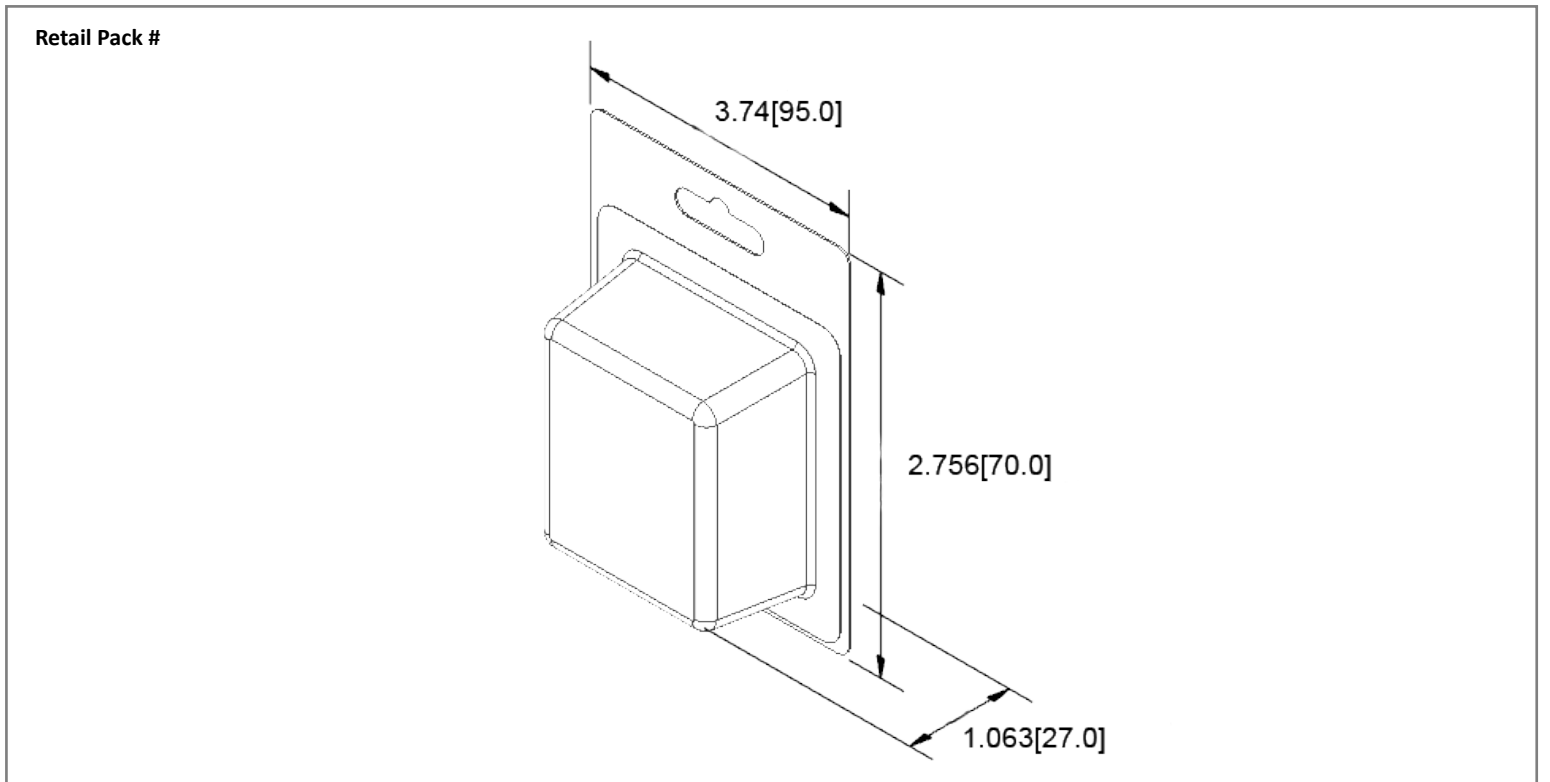

Disclaimer: Information provided is believed to be accurate and reliable. Users are responsible for confirming the suitability and performance of any OptiFuse product for their particular application. These products may not be appropriate for every use, and proper evaluation is recommended before implementation. For additional information, please visit optifuse.com/product-disclaimer.

Specifications are subject to change without notice

Rev	Date of issue	Revision Notes	Designed	Approved
I	02-27-2026	Updated Parts Number Information	RC	OF