

Type ANM125-M Automotive Blade Fuse Miniature



www.optifuse.com (619) 593-5050

Specifications:

- Voltage: 125VDC
- Amperage: 3A, 4A, 5A, 7.5A, 10A, 15A
- Body: Nylon with 25% Fiberglass UL 94V-0
- Cover: Nylon with 25% Fiberglass, Dark Red, UL 94V-0
- Terminals: Copper alloy, Tin plated
- Interrupt Rating – 1000A @ 125 VDC

Part Number	Amperage	Body Color
ANM125-M-3A	3A	Violet
ANM125-M-4A	4A	Pink
ANM125-M-5A	5A	Tan
ANM125-M-7.5A	7.5A	Brown
ANM125-M-10A	10A	Red
ANM125-M-15A	15A	Blue

Time Characteristics:		
% of Rated Current	Min Hold Time	Max Hold Time
110%	100h	~
150%	500ms	600s
200%	150ms	30s
350%	40ms	500ms
600%	15ms	100ms

Mechanical Dimensions: Inches [mm]

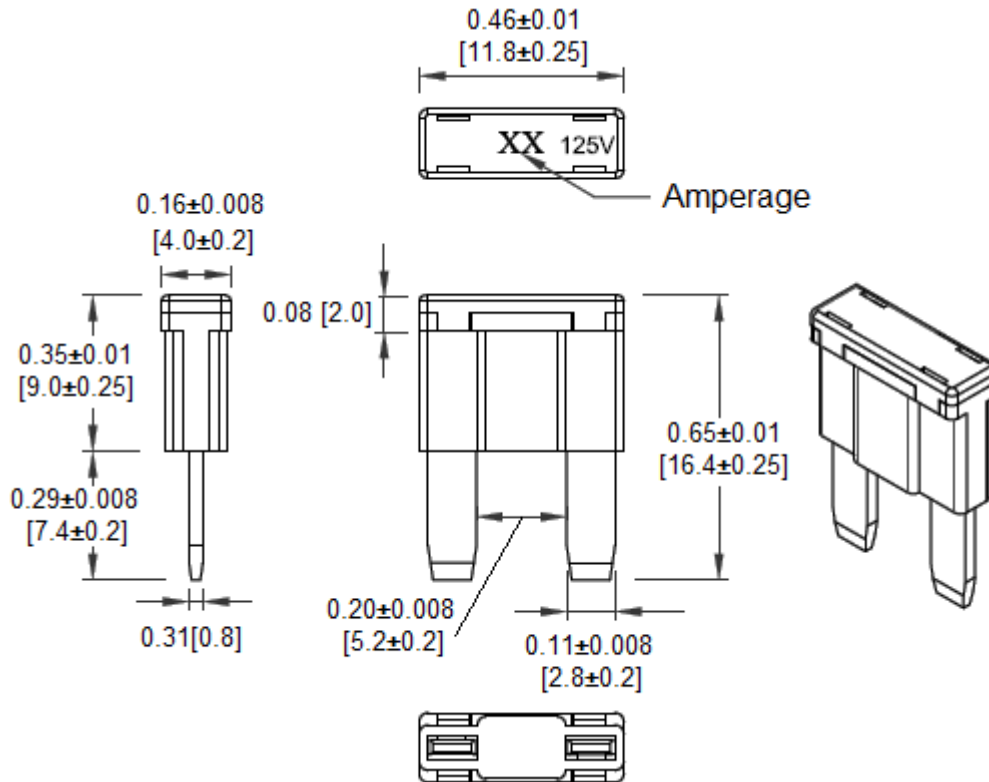

Warning:



- Operation beyond the specified maximum ratings or improper use may result in damage and possible electrical arcing and/or flame.
- Avoid contact of device with chemical solvent. Prolonged contact will damage the device performance.