

### Mechanical Dimensions: Inches [mm]

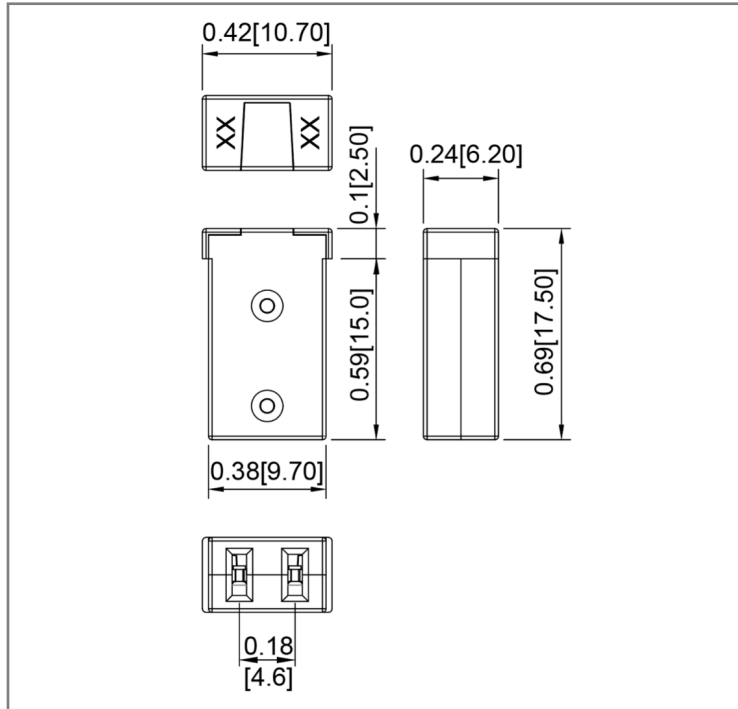

### Retail Pack: Inches [mm]

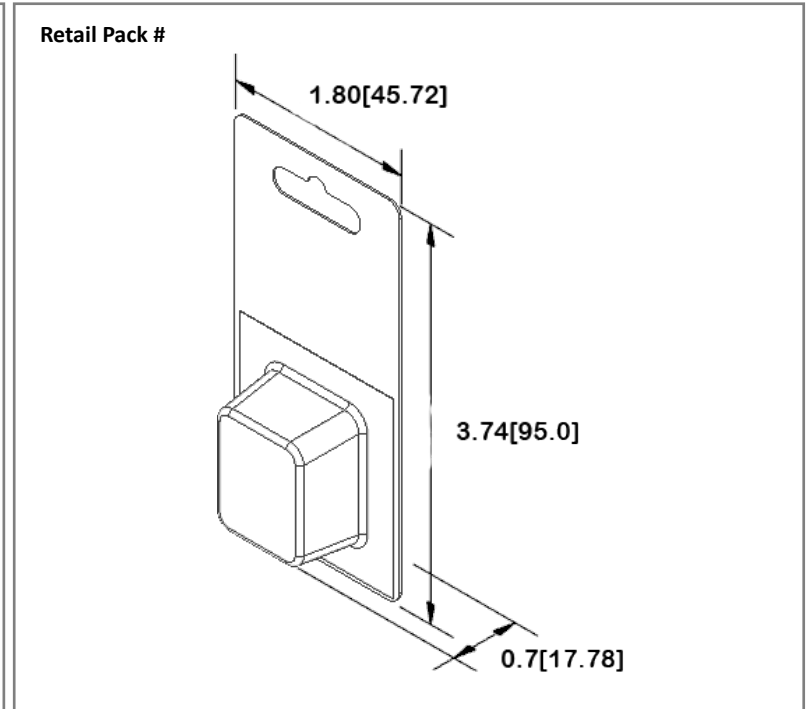

### Part Numbers Information

Amperage	Body Color	Bulk Part #	Retail Pack # Blister Card	Pack Size
15A	Gray	FMX-M-15A	FMX-M-15A-BP	1
20A	Blue	FMX-M-20A	FMX-M-20A-BP	1
25A	White	FMX-M-25A	FMX-M-25A-BP	1
30A	Pink	FMX-M-30A	FMX-M-30A-BP	1
40A	Green	FMX-M-40A	FMX-M-40A-BP	1

### Electrical Specifications

Voltage Rating	58VDC
Interrupting Rating	1000A @58VDC
Operation Temperature	-40°F~260°F

### Material Specifications

Body Material	Nylon with Fiberglass
Cover Material	Nylon 66
Insertion Force	45N Max.
Extraction Force	45N Min. / 35N Max.

### Mounting Hole

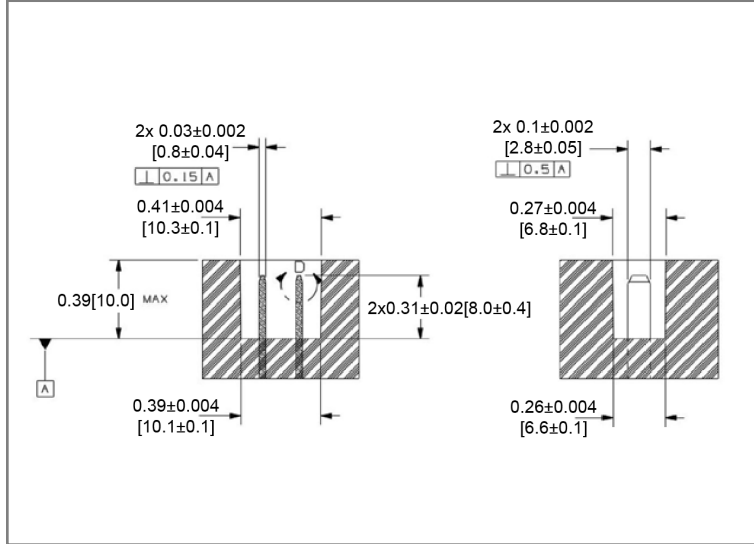

### Time vs. Percent of Rated Current

% of Rated Current	Min Hold Time	Max Hold Time
110%	4hr	-
135%	60s	1800s
200%	2s	60s
350%	200ms	7s
600%	40ms	1s

### Rev Date of issue Revision Notes

### Designed Approved

C	05-22-2023	Initial Drawing	RC	OF
---	------------	-----------------	----	----