

Mechanical Dimensions: Inches [mm]

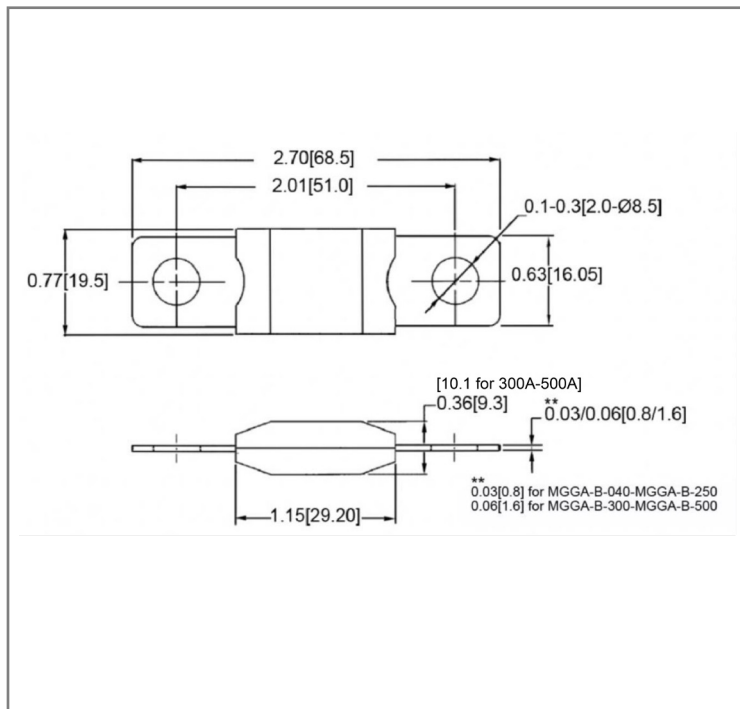

Retail Pack: Inches [mm]

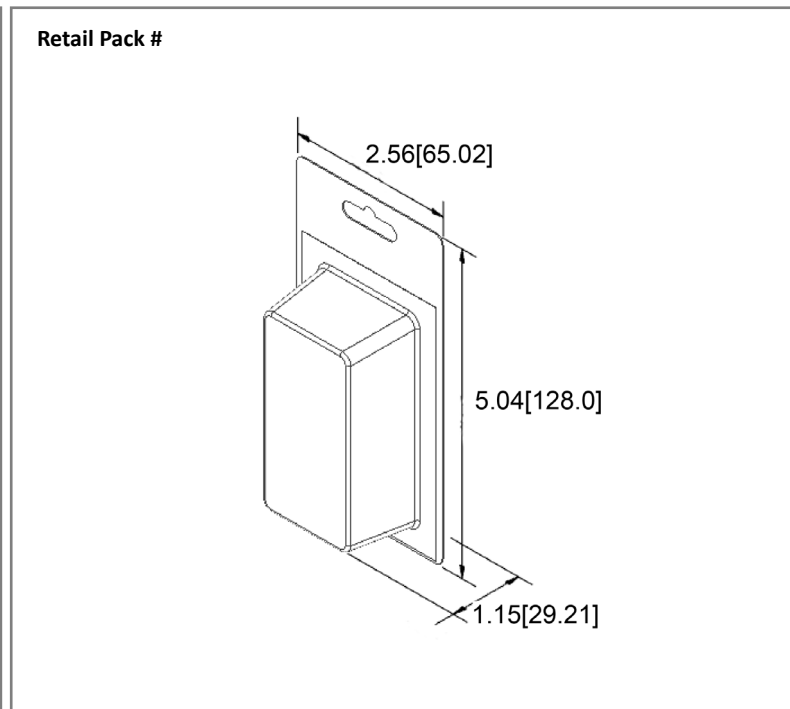

Part Numbers Information

Amperage	Bulk Part #	Retail Pack # Blister Card	Pack Size
40A	MGGA-40A-B	-	-
50A	MGGA-50A-B	-	-
60A	MGGA-60A-B	-	-
70A	MGGA-70A-B	-	-
80A	MGGA-80A-B	MGGA-80A-BP	1
90A	MGGA-90A-B	-	-
100A	MGGA-100A-B	MGGA-100A-BP	1
125A	MGGA-125A-B	MGGA-125A-BP	1
150A	MGGA-150A-B	MGGA-150A-BP	1
175A	MGGA-175A-B	MGGA-175A-BP	1
200A	MGGA-200A-B	MGGA-200A-BP	1
225A	MGGA-225A-B	MGGA-225A-BP	1
250A	MGGA-250A-B	MGGA-250A-BP	1
300A	MGGA-300A-B	MGGA-300A-BP	1
400A	MGGA-400A-B	-	-
500A	MGGA-500A-B	-	-

Electrical Specifications

Voltage Rating	32VDC
Interrupting Rating	2000A@32VDC
Operation Temperature	-40°C ~ 125°C
Testing	ISO 8820-5

Material Specifications

Body Material	PPA-GF33FR (UL 94V-0)
Body Color	Black
Terminals	Copper with tin plated
Mounting Hole Size	M8
Mounting Torque	~12-18 Nm

Time vs. Percent of Rated Current

% of Rated Current	Current Rating	Min Hold Time	Max Hold Time
75%	40A~250A	-	-
	300A~500A	14400s	-
100%	40A~250A	14400s	-
	300A~500A	-	-
135%	40A~250A	120s	1800s
	300A~500A	-	-
200%	40A~250A	1s	15s
	300A~500A	1s	15s
350%	40A~250A	0.3s	5s
	300A~500A	0.5s	5s
600%	40A~250A	0.1s	1s
	300A~500A	-	-

Rev	Date of issue	Revision Notes	Designed	Approved
E	09-25-2023	update information	RC	OF