

# Type PMA-DS-02-Q1S

## Panel Mount Fuse Holder

### 1/4" x 1 1/4" (6.3 x 32mm) Fuses

### Driver / Screw



www.optifuse.com

(619) 593-5050

**Electrical Rating:** 15A, 250V AC

**Fuse Style:** 1/4" x 1 1/4" (6.3 x 32mm)

**Material:**

**Frame:** Phenolic (UL flame: 94V-1)

**Cap:** PBT (UL flame: 94V-0)

**Terminals:** Nickel-plated brass

**Cap:** Slotted Driver type, Screw type

**Mounting:** by nut

**Terminal:** Solder/Quick-Connect 4.8mm / 0.187"

**Panel Thickness:** 0.5 ~ 4mm

**Agency Standards and Listings:**



**Product Dimensions: Inches [mm]**

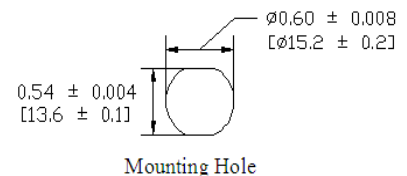
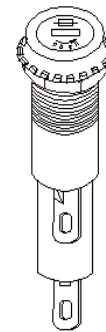
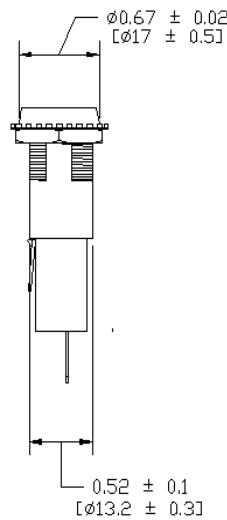
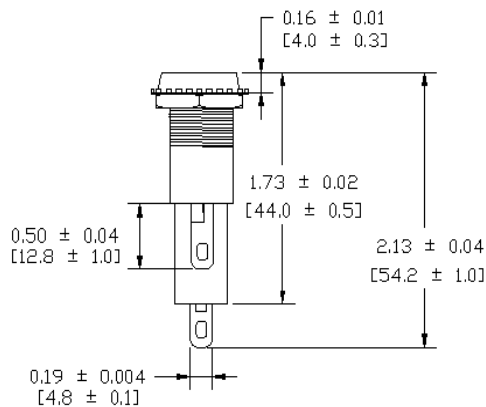

**Warning:**



- Operation beyond the specified maximum ratings or improper use may result in damage and possible electrical arcing and/or flame.
- Fuse Holders are not intended for circuit disconnect. All power should be disconnected before removing fuse.
- Avoid contact of Fuse Holder with chemical solvent. Prolonged contact may damage the device performance.