

Type TMR-BP

Time Lag Micro Fuse

Radial Leaded – Long Leaded

For Ballast Protection Applications



www.optifuse.com

(619) 593-5050

Agency Standards and Listings:



PSE 1A~6.3A

Interrupt Ratings:

PSE - 50A 300 VAC

Operating Temperature: -55°C ~ +125°C

Packaging:

On Tape: Ammo Pack, 1,000 pcs per box

Physical Specifications (Materials):

Thermoplastic Body, UL 94-V0

Tin-Lead Plated Alloy Pins

Electrical Characteristics:

2.1 In		2.75 In		4 In		10 In	
MAX	MIN	MAX	MIN	MAX	MIN	MAX	MIN
2 min	400ms	10Sec	150ms	3 Sec	20 ms	150 ms	

Part Number	Ampere Rating	Voltage Rating	I ² T
TMR-BP-100mA	100mA	300VAC	0.02623
TMR-BP-125mA	125mA		0.04499
TMR-BP-160mA	160mA		0.08755
TMR-BP-200mA	200mA		0.1181
TMR-BP-250mA	250mA		0.2030
TMR-BP-315mA	315mA		0.3597
TMR-BP-400mA	400mA		0.6893
TMR-BP-500mA	500mA		1.232
TMR-BP-630mA	630mA		2.185
TMR-BP-800mA	800mA		2.987
TMR-BP-1A	1A		6.319
TMR-BP-1.25A	1.25A		12.23
TMR-BP-1.6A	1.6A		22.03
TMR-BP-2A	2A		43.08
TMR-BP-2.5A	2.5A		50.05
TMR-BP-3.15A	3.15A		73.53
TMR-BP-4A	4A		88.16
TMR-BP-5A	5A		152.0
TMR-BP-6.3A	6.3A	255.7	

Mechanical Dimensions: Inches [mm]

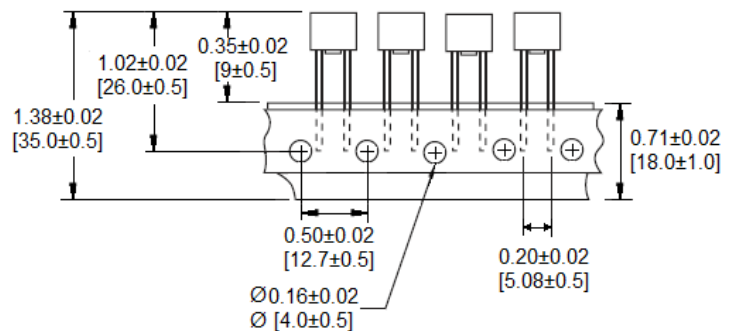
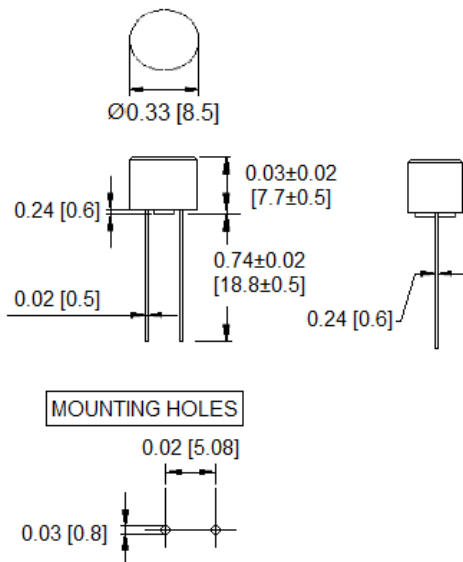

Warning:

- Operation beyond the specified maximum ratings or improper use may result in damage and possible electrical arcing and/or flame.
- Micro Fuse device are intended for occasional overcurrent protection. Application for repeated overcurrent condition and/or prolonged trip are not anticipated.
- Avoid contact of Micro Fuse device with chemical solvent. Prolonged contact will damage the device performance.